

THE NEW VALUE FRONTIER

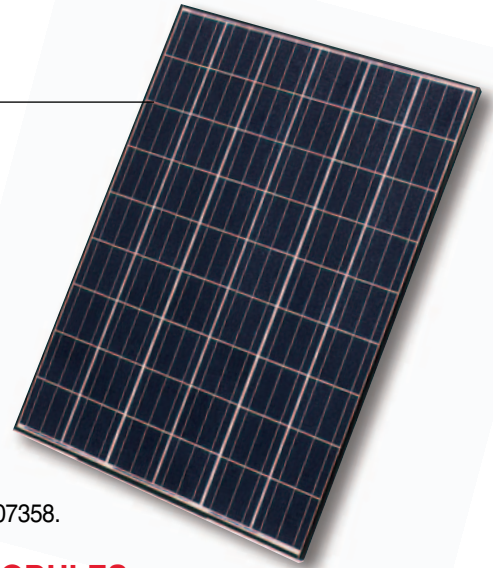

# KC200GHT-2

HIGH EFFICIENCY POLYCRYSTALLINE PHOTOVOLTAIC MODULE



Kyocera is "ISO9001" certified and registered.

TUVdotCOM Internet platform for tested quality and service ID 000007358.

## HIGHLIGHTS OF KYOCERA PHOTOVOLTAIC MODULES

Kyocera's advanced cell processing technology and automated production facilities produce a highly efficient polycrystalline photovoltaic module.

The conversion efficiency of the Kyocera solar cell is over 16%.

These cells are encapsulated between a tempered glass cover and a pottant with back sheet to provide efficient protection from the severest environmental conditions.

The entire laminate is installed in an anodized aluminum frame to provide structural strength and ease of installation. Equipped with plug in connectors.

## APPLICATIONS

### Grid-Connected Systems

- Residential Solar Power Systems
- Public and Industrial Solar Power Systems

### Stand-Alone Solar Power Systems for

- Villages in remote areas
- Homes and summer cottages
- Microwave / Radio repeater stations
- Medical facilities in rural areas

- Emergency communication
- Water quality and environmental data monitoring
- Drinking water and livestock water pumping
- Irrigation pumping
- Cathodic protection
- Aviation obstruction lights
- Environmental data monitoring
- Railway signals
- Street lighting
- Desalination
- etc.

## LIMITED PERFORMANCE WARRANTY

※2 years limited warranty on material and workmanship

※25 years limited warranty on power output.

(Long term output warranty shall guarantee that loss of output is not more than 10% of the minimum warranty value of the product specifications within 12 years and is not more than 20% within 25 years after the purchase of the product by customer. The output values shall be those measured under Kyocera standard measurement conditions. Regarding the warranty conditions in detail, please refer to Warranty issued by Kyocera.)

## ELECTRICAL CHARACTERISTICS

Current-Voltage characteristics of Photovoltaic Module KC200GHT-2 at various cell temperatures

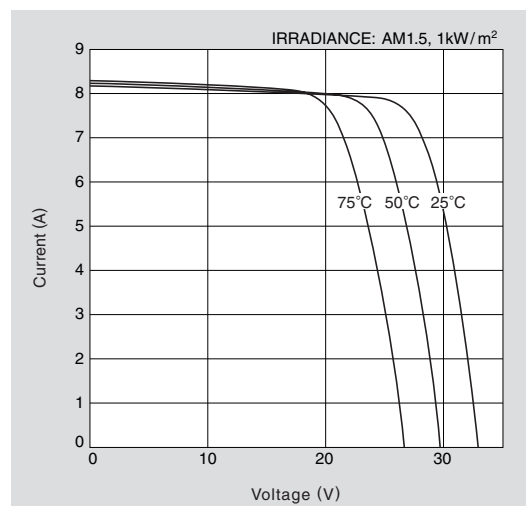

Current-Voltage characteristics of Photovoltaic Module KC200GHT-2 at various irradiance levels

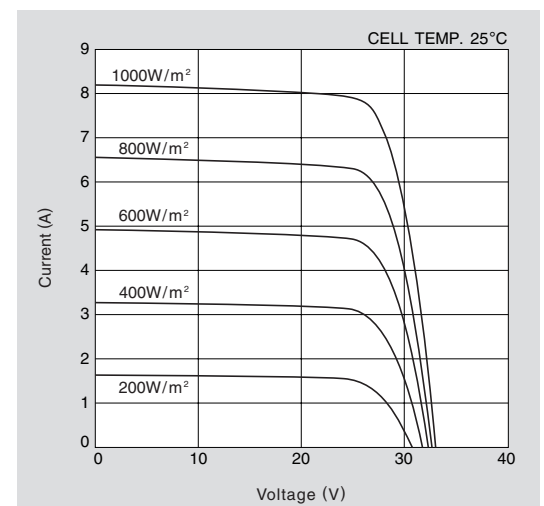

MODEL  
KC200GHT-2

**Physical Specifications**

(Unit : mm)

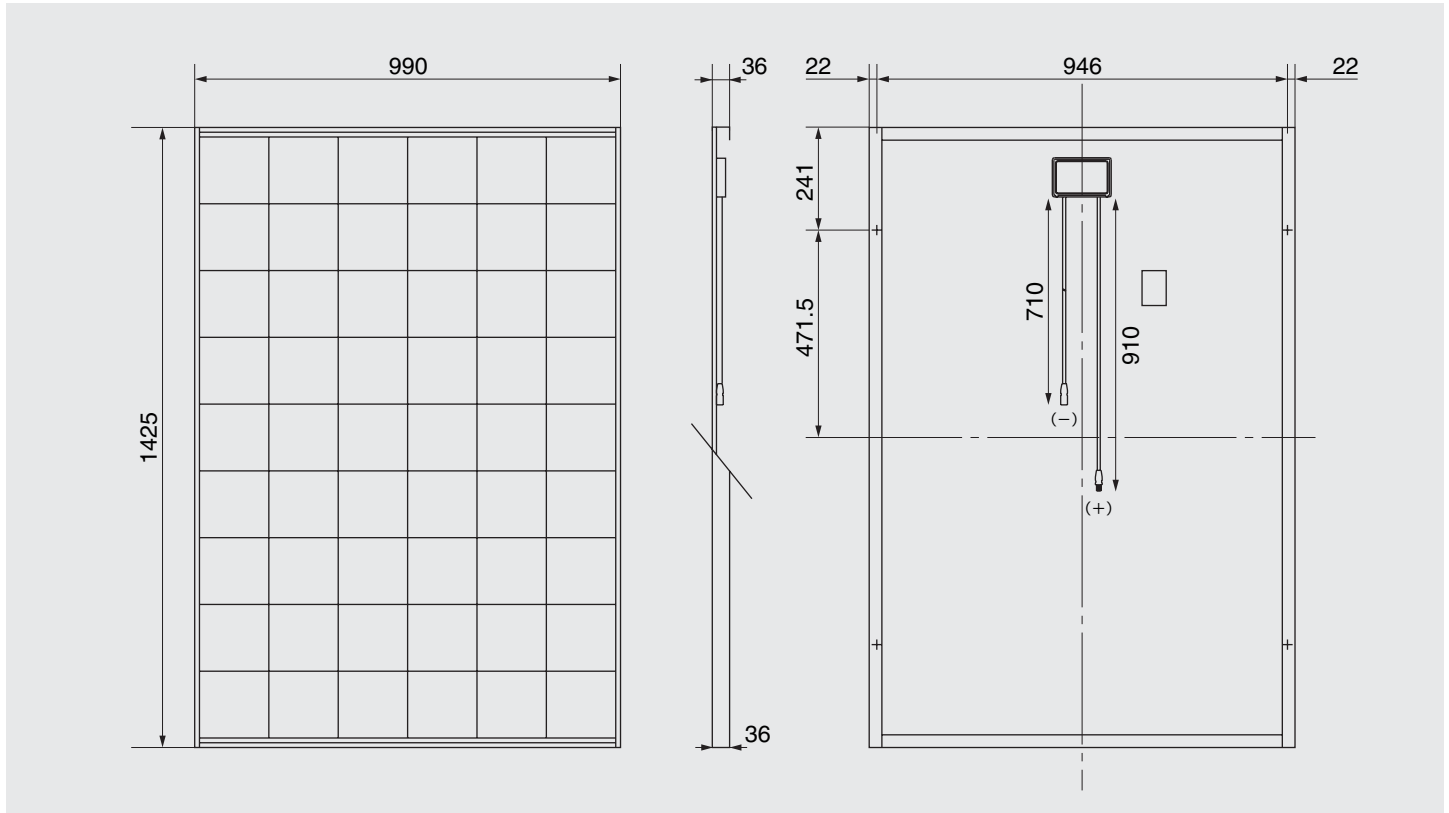

**Specifications**

Electrical Data		
Maximum Power(Pmax)	[ W ]	200
Tolerance	[ % ]	+10/-5
Maximum Power Voltage	[ V ]	26.3
Maximum Power Current	[ A ]	7.61
Open Circuit Voltage (Voc)	[ V ]	32.9
Short Circuit Current (Isc)	[ A ]	8.21
Temp. coefficient of Voc	[ V/°C ]	-1.23×10 <sup>-1</sup>
Temp. coefficient of Isc	[ A/°C ]	3.18×10 <sup>-3</sup>
NOCT	[ °C ]	47
Max System Voltage	[ V ]	1000

Dimension		
Length	[ mm ]	1425
Width	[ mm ]	990
Depth without box	[ mm ]	36
Weight	[ kg ]	18.5
Cable	[ mm ]	(+)910/(-)710

Cells	
Number per module	54
Cell Technology	Polycrystalline
Cell Shape	Rectangular

Note : The electrical specifications are under test conditions of Irradiance of 1kw/m<sup>2</sup>, Spectrum of 1.5 air mass and cell temperature of 25°C.  
Kyocera reserves the right to modify these specifications without notice.

Please contact our office to obtain details without hesitation.



**KYOCERA Corporation**

**KYOCERA Corporation Headquarters**

CORPORATE SOLAR ENERGY DIVISION  
6 Takeda Tobadono-cho  
Fushimi-ku, Kyoto  
612-8501, Japan  
TEL:(81)75-604-3476 FAX:(81)75-604-3475  
<http://www.kyocera.com>

● **KYOCERA Fineceramics GmbH**

Fritz Muller strasse 107, D-73730 Esslingen, Germany  
TEL:(49)711-9393417 FAX:(49)711-9393450  
<http://www.kyocerasolar.de/>

● **KYOCERA Asia Pacific Pte. Ltd.**

298 Tiong Bahru Road, #13-03/05  
Central Plaza, Singapore 168730  
TEL:(65)6271-0500 FAX:(65)6271-0600

● **KYOCERA Solar, Inc.**

7812 East Acoma Drive  
Scottsdale, AZ 85260, USA  
TEL:(1)480-948-8003 or (800)223-9580 FAX:(1)480-483-6431  
<http://www.kyocerasolar.com>

● **KYOCERA(Tianjin) Sales & Trading Corporation**

Add:19F, Tower C HeQiao Building 8A GuangHua Rd.,  
Chao Yang District, Beijing 100026, China  
TEL:(86)10-6583-2270 FAX:(86)10-6583-2250